

Laia dossier haut piètement roulettes

Design by Jean Louis Iratzoki



La dernière née de la collection Laia est une chaise de bureau. De nombreuses parties de cette chaise sont personnalisables: la hauteur de dossier, la base (giratoire de 5 branches ou fixe de 4 branches) ou encore l'assise qui peut être tapissée de tissu, cuir ou de simili cuir. Comme pour la chaise, la face arrière reste toujours en feutre.

CATÉGORIE :
Chaise bureau

ENVIRONNEMENT :
Indoor

APPLICATIONS :
— CHR
— Public
— Office

POIDS : 9,5 kg

MATÉRIAUX :
Version 5 branches à roulettes en métal chromé mat avec vérin pour réglage de la hauteur d'assise de 440 mm à 560 mm. Assise sandwich sur support multi-plies, tapissé en deux verisons : Face avant en Europost,

Capture, Remix 2, Crisp, Palma, Palma NF, Crisscross, Canvas 2, Molly 2, Luna 2, Steelcut Trio 3 et Gracia, face arrière en feutre naturel * (coloris naturel gris/brun) ép. 4 mm. Version recto & verso en Europost, Palma, Palma NF, Luna 2 et Gracia, avec feutre naturel entre.

EN OPTION : Mousse CMHR (non feu)

A LA COMMANDE : Finitions et revêtements voir page 2

PIÈCES DE RECHANGE : N/A

PRODUIT ASSEMBLÉ : Oui

REVÊTEMENT CLIENT :

Possible avec accord préalable alki

- **Laia face avant :** Tissu 1,00 x 1,40 mts / 2 chaises
Cuir 5m² / 5 chaises
- **Laia recto & verso :** Tissu 1,00 x 1,40 mts / chaise
Cuir 5m² / 2 chaises

ENTRETIEN :

Uniquement microfibre à peine humide + sécher au chiffon. Ne pas utiliser de produits qui contiennent du silicone. Pour les produits tapissés, veuillez suivre les instructions d'entretien du fabricant tissu sur kvadrat.dk, gabriel.dk, anticcuir.com and hornsusch.com

TÉLÉCHARGEMENTS :

Fichiers 3D et 2D sont disponibles sur alki.fr section banque d'images.

DIMENSIONS :

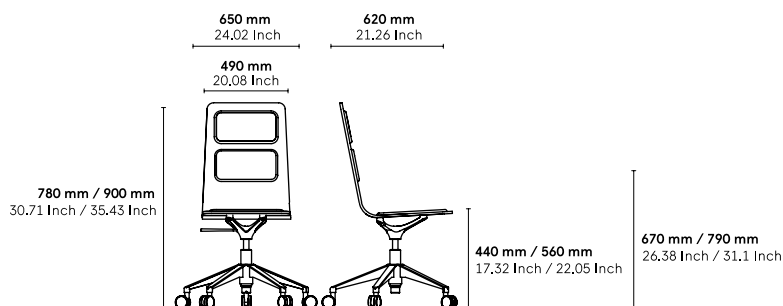

Document non contractuel, modifiable sans préavis.

Finitions

Natural Wool Felt



Natural Wool Felt

Eco Leather

G1: Toronto | G2: Palma NF



Toronto White Toronto Pearl Toronto Birch Toronto Cappuccino Toronto Carob Toronto Chestnut



Toronto Cherry Toronto Ashgrey Toronto Cashmere Toronto Mocca Toronto Anthracite Toronto Corn



Palma NF Smoke Palma NF Schwartz Palma NF Baltic

Leather

G4: Gracia



Gracia 117 Gracia 902 Gracia 903 Gracia 908 Gracia 911



Gracia 913 Gracia 925 Gracia 930 Gracia 942 Gracia 943

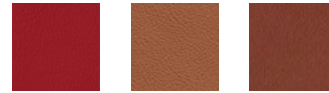

Gracia 945 Gracia 1967 Gracia 1920

Fabrics by Gabriel

G1: Europost, Crisp, Capture, Focus | G2: Morph | G3: Luna, Focus M.



Focus 60209 Focus 61035 Focus 661036 Focus 61040 Focus 61043 Focus 66011



Capture 4101 Capture 4201 Capture 4301 Capture 5001 Capture 5101 Capture 6301

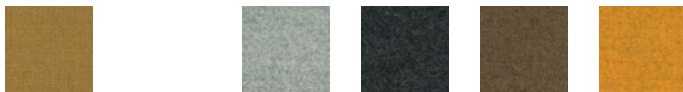

Capture 6801 Focus Melange 60310 Focus Melange 60900 Focus Melange 61237 Focus Melange 62117



Crisp 4021 Crisp 4033 Crisp 4034 Crisp 4115 Crisp 4430 Crisp 4432



Crisp 4701 Crisp 4741 Morph 5101 Morph 12101 Morph 14101



Luna 4204 Luna 4301 Luna 4811 Luna 4812 Europost 61003

Laia Collection

Design by Jean Louis Iratzoki

SEATING

- Chairs
- Working Chairs
- Meeting Chairs
- Benches
- Stools

TABLES

- Desk Tables
- Meeting Tables
- High Working Tables
- Dining Tables
- High Dining Tables
- Low Tables

Chairs



Stools



Working Chairs



Meeting Chairs



Benches



Desk Tables



Meeting Tables



High Working Tables



Dining Tables



High Dining Tables



Low Tables

